

Hopkins County, KY PVA

Summary

Parcel Number MAP-104-23
Account Number 38576
Location Address EASTLAWN RD 01935
Description
(Note: Not to be used on legal documents)
Class Farm
Tax District 01 County
2020 Rate Per Thousand 10.1410

[View Map](#)



Owner

Primary Owner
 MILLER ANNELLE & SUELLEN BLUE &
 MARK O BLUE & J LINDSAY BLUE
 1935 EASTLAWN RD
 MADISONVILLE, KY 42431-

Land Characteristics

Condition	Good	Topography	Rolling
Plat Book/Page		Drainage	Natural
Subdivision		Flood Hazard	
Lot		Zoning	Other
Block		Electric	Yes
Acres	54.00	Water	Yes
Front	0	Gas	No
Depth	0	Sewer	No
Lot Size	0x0	Road	2 Lane
Lot Sq Ft	0	Sidewalks	Rural
Shape		Information Source	

Valuation

	2023 Certified	2022 Certified	2021 Certified	2020 Certified
+ Land Value	\$13,300	\$13,300	\$13,300	\$13,300
+ Improvement Value	\$87,700	\$87,700	\$87,700	\$87,700
+ Ag Improvement Value	\$0	\$0	\$0	\$0
= Total Taxable Value	\$101,000	\$101,000	\$101,000	\$101,000
- Exemption Value	(\$46,350)	(\$40,500)	(\$40,500)	(\$39,300)
= Net Taxable Value	\$54,650	\$60,500	\$60,500	\$61,700
+ Land FCV	\$63,600	\$63,600	\$63,600	\$63,600
+ Improvement FCV	\$87,700	\$87,700	\$87,700	\$87,700
+ Ag Improvement FCV	\$0	\$0	\$0	\$0
= Total FCV	\$151,300	\$151,300	\$151,300	\$151,300
Exemption	HX	HX	HX	HX
Farm Acres	54.00	54.00	54.00	54.00
Fire Protection Acres	3.00	3.00	3.00	3.00

Taxes

	2020	2019
Tax	\$670.71	\$486.16

Improvement Information

Building Number	1	Kitchens	0
Description	HOUSE	Dining Rooms	0
Residence Type	Single Family	Living Rooms	0
Comm Type		Family Rooms	0
Mobile Home Type		Bedrooms	3
Year Built	1919	Full Baths	2
Effective Age	0	Half Baths	0
Ave. Wall Height	0	Other Rooms	1
Structure	1 Story	Total Rooms	5
Number of Stories	1	Living Sq Ft	1,652
Exterior	Vinyl	Fireplaces/Water	1/1
Foundation	Brick/Stone	Supplemental Heat	
Construction Type	Wood Frame	Mobile Home Model	
Construction Quality	Average/Standard	Mobile Home Manufacturer	
Building Condition	Average	MH Skirt Foundation	
Roof Type	Gable	Heat	Yes
Roof Cover	Comp.Shingles	Heat Source	Natural Gas
Roof Pitch	High	Heat Type	Forced Air
Basement Type	None	Air Conditioning	Yes
Basement Finish		AC/Type	Central
Basement Size		Special Improvements	No
Basement Sq Ft	0	Fire Alarm	No
Garage/Carport	Garage	Sprinklers	No
Garage Size	2 Car	Porch/Deck	
Garage Type	Attached	Porch Sq Ft	290
Garage Exterior	Vinyl	Deck Sq Ft	0
Width	0	Concrete Sq Ft	0
Length	0	Farm Bldg Type	
Garage Sq Ft	0	Value	\$102,600.00
Pool	None	Driveway	Gravel
Pool Size	0	Fence	0
Tennis Courts	None		

Photos



Sketches

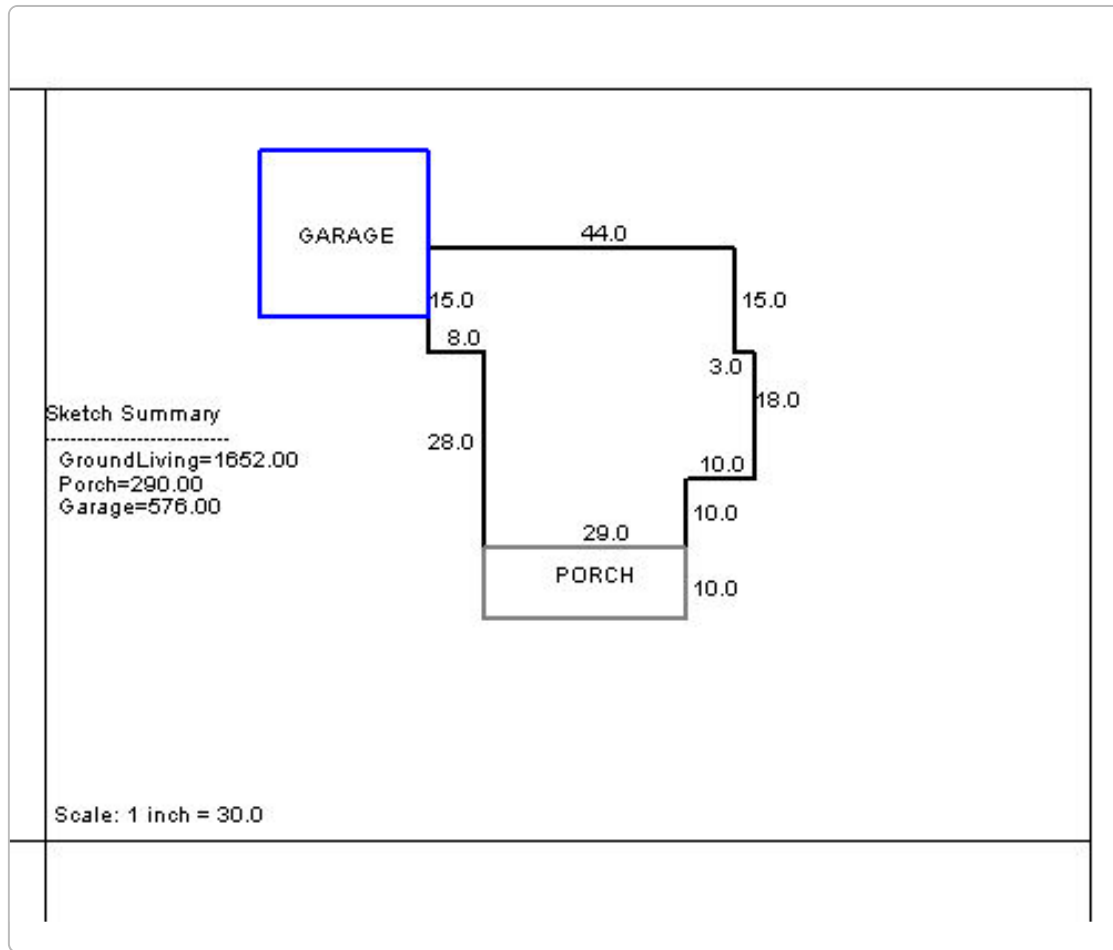

Sale Information

Sale Date	Sale Price	Sale Type	Book-Page	Grantee	Grantor
1/1/2024	\$0	Close Relative Sale	687-248	MILLER ANNELLE - ET AL	
11/23/2009	\$0	Close Relative Sale	687-248	BLUE BETTY S (LIFE ESTATE)	BLUE BETTY S
12/1/1962	\$13,500		280-240	BLUE BETTY S & WILLIAM	ADAMS HOMER L
12/1/1958	\$0		272-620	ADAMS HOMER L	ADAMS HERMAN
1/1/1957	\$0		169-375	ADAMS HERMAN	



[User Privacy Policy](#) [GDPR Privacy Notice](#)
Last Data Upload: 8/2/2024, 2:10:04 PM