

SURVEY REFERENCES:
 G-233, H-93, H-96,
 I-198, R-249A, O-184A

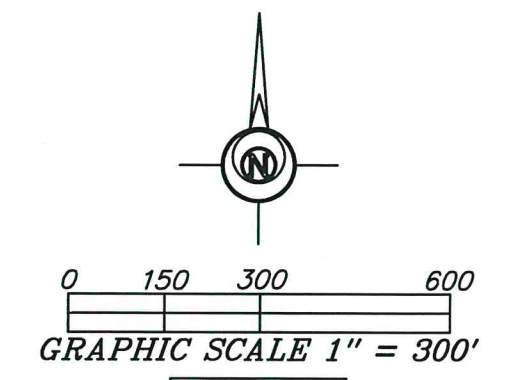

LEGEND

- 5/8 INCH REBAR W/ID CAP SET
- 1/2 INCH REBAR FOUND
- ⊗ RAILROAD SPIKE FOUND
- ∅ METAL SURVEY STAKE FOUND
- [M+S] MAG NAIL + SHINER FOUND
- [MAGS] MAG NAIL SET
- [MSPK] MINE SPIKE FOUND
- LCE 3 INCH DISC IN MONUMENT BOX
- DNR 3 INCH DISC ON CONCRETE MONUMENT
- ⊗ 1.25 INCH IRON PIPE IN MONUMENT BOX
- POB POINT OF BEGINNING
- POC POINT OF COMMENCEMENT

NOTE: SURVEY BEARINGS BASED ON OHIO NORTH ZONE STATE PLANE COORDINATES OBTAINED FROM THE OHIO DOT VRS NETWORK

THIS SURVEY WAS PERFORMED WITHOUT THE BENEFIT OF A TITLE EXAMINATION. BEYOND THE DEED DOCUMENTS CITED ON THE SURVEY DRAWING THERE MAY BE RECORDED OR UNRECORDED EASEMENTS AND/OR ENCUMBRANCES BENEFITING OR ENCUMBERING THE SURVEYED PROPERTY WHICH ARE NOT SHOWN ON THIS DRAWING.

FILENAME: 24-203-BDL-8-15-24.scj DATE: 8/9/24

SURVEY PLAT FOR:
 NORMAN MERCER

PART OF THE N 1/2 OF THE NE 1/4,
 SECTION 12, T6N-R8E,
 SWAN CREEK TOWNSHIP, FULTON COUNTY, OHIO

Bockrath & Associates
 Engineering and Surveying, LLC
 115 S. Fair Avenue, Suite A - Ottawa - Ohio
 Phone: 419.523.5789

I HEREBY CERTIFY THIS TO BE A SURVEY MADE UNDER MY SUPERVISION AND THAT THE MONUMENTS ARE FOUND AND/OR SET AS INDICATED.

8-20-24
 Date
 Seth D. Schroeder, P.S.
 Registered Surveyor No. 8784
 115 S. Fair Avenue, Suite A
 Ottawa, Ohio 45875
 419-523-5789

