

Summary

Map Number/Account Number 243-00 02 123.00 / 623410001
 Tax District City of Hopkinsville (01)
 Description 213 MARK DR L70 COUNTRY MEADOWS SUBD B4
 (Note: Not to be used on legal documents)
[See Tax Rates](#)
 Tax Rates 213 MARK DR
 Location Address 572
 Deed Book 420
 Deed Page

[View Map](#)



Owner

Wagner Evelyn A Royalty Estate
 213 Mark Dr
 Hopkinsville KY 42240

Value Information

	2023 Working Tax Roll Assessment	2022 Certified Tax Roll Assessment
Residential Value	\$160,000	\$160,000
Commercial Value	\$0	\$0
Mobile Home Value	\$0	\$0
Farm Tax Value	\$0	\$0
Farm Fair Cash Value	\$0	\$0
TC Build Value	\$0	\$0
TC Land Value	\$0	\$0
LS Hold Value	\$0	\$0
Homestead	No	No

Most Recent Sale

Sale Date	Sale Price	Deed Book	Deed Page	Previous Owner
10/1/2000	\$106,900	572	420	WAGNER EVELYN A ROYALTY

Land Information

Class	RESIDENTIAL	Sidewalks	N
Lot Size	0	Topography	
Frontage	0	Zoning Code	
Depth	0	Subdivision	COUNTRY MEADOWS
Acreage	0	Unit	
Type	RESIDENTIAL	Block	
Drive Type	A	Lot	70
Flood Type		Land Value	\$0
Utility Type	W		

Residential Improvement Information

Res Type	SINGLE FMLY	Heat	GAS
Year Built	0	AC	CENTRAL
Foundation	BRICK ON BLOCK	Total Rooms	0
Basement	NONE	Value	\$0
Exterior	BRICK	Living Sqft	1822
Bedrooms	3	Basement Sqft	0
Full Bath	2	Garage Sqft	484
Half Bath	0	Porch Sqft	0
Roof Cover	CPSN SHGLS	Patio/Deck Sqft	0
Roof Type	GABLE	Basement Finish	0
Res Cond		Structure	1 STORY
Fireplaces	0	Garage	ATTCHD 2 CAR

Sale Information

Sale Date	Sale Price	Deed Book	Deed Page	Previous Owner
10/1/2000	\$106,900			SCHNECK CLAUDE C
1/1/1990	\$80,000			FAYE E THOMAS

Recent Sales In Area

Sale date range:

From: To:

Photos



Sketches

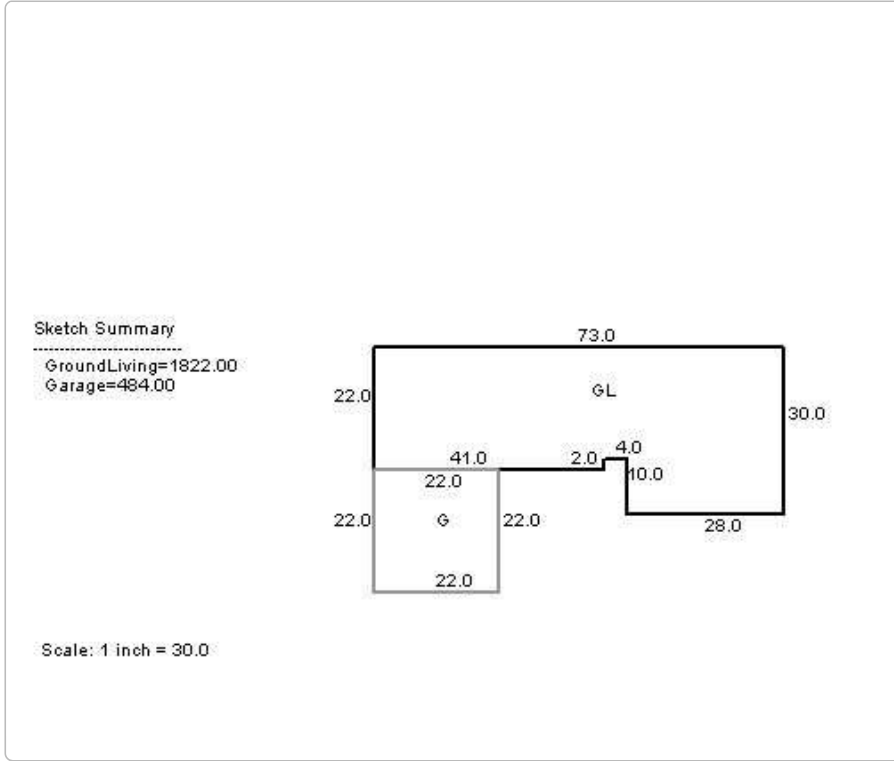

No data available for the following modules: Mobile Home Information, Commercial Information.

The Christian County Assessor's Office makes every effort to produce the most accurate information possible. No warranties, expressed or implied, are provided for the data herein, its use or interpretation.
[User Privacy Policy](#)
[GDPR Privacy Notice](#)

Last Data Upload: 5/26/2023, 1:18:44 PM