

5 DEPOT RD

Location 5 DEPOT RD

Parcel No. 020/A 3/ /41 /

Acct# 2226

Owner MYERS, MICHAEL T. 1/2

Assessment \$104,400

PID 10740

Building Count 1

Legal Description 20A-(3)-41 WEYERS CAVE
INTERSEC OF RTS 256&769
0.744ACRE

District 02: Middle River

Current Value

Assessment			
Valuation Year	Improvements	Land	Total
2021	\$59,400	\$45,000	\$104,400

Parcel Addresses

Additional Addresses

No Additional Addresses available for this parcel

Owner of Record

Owner	MYERS, MICHAEL T. 1/2	Sale Price	\$0
Co-Owner	BALL, MIRANDA MYERS 1/4 ET AL	Recorded	2023
Address	P. O. BOX 134	Book & Page	/
	WEYERS CAVE, VA 24486	Sale Date	08/11/2023

Ownership History

Ownership History					
Owner	Sale Price	Recorded	Book & Page	Sale Date	Instrument No
MYERS, MICHAEL T. 1/2	\$0	2023	/	08/11/2023	230028382
MYERS, EVELYN ELIZABETH	\$0	2023	/	08/10/2023	230028381
MYERS, RAY G.	\$0	0	433/443	01/01/1957	000000000
MYERS, RAY G.	\$0	0	433/443	01/01/1957	000000000
HARRISONBURG TELEPHONE CO.	\$0	0	189/61	01/01/1957	000000000

Building Information

Building 1 : Section 1

Year Built: 1900
Living Area: 1,332

Building Attributes	
Field	Description

Model	Residential
Style	Residential
Grade	Grade C
Grade Adjust	0.00
Stories	1
Num Units	0
Roof Type	Gable
Roof Cover	Metal/Tin
Exterior Wall 1	Stucco/Masonry
Exterior Wall 2	
Heat System	Forced Air
Heat Fuel	Oil
AC Type	FULL
Interior Wall 1	Plaster
Interior Wall 2	
Interior Wall 3	
Interior Floor 1	Carpet
Interior Floor 2	
Interior Floor 3	
Total Room(s)	5
Bedroom(s)	3
Full Bath(s)	1
Half Bath(s)	0
Extra Fixture(s)	0
Extra Kitchen(s)	0

Building Photo



https://images.vgsi.com/photos/AugustaVAPhotos/AP002\0002226_01_01

Fireplace(s)	0
Stacked Fireplace(s)	0
Gas Fireplace(s)	4
Flue(s)	0
Metal Flue(s)	0
Inop Flue/FPL	0
Legacy Area	1332
Foundation	Conc/Block
Basement	Crawl
Fin Bsmt Area	0
FBM Quality	
Num Cars - Built In	0
Garage Type	None
Num Cars - Garage	0
Carport Type	None
Num Cars - Carport	0
Garage Type 2	
Num Cars - Garage 2	0
Split Foyer	No
Split Level	No

Building Layout

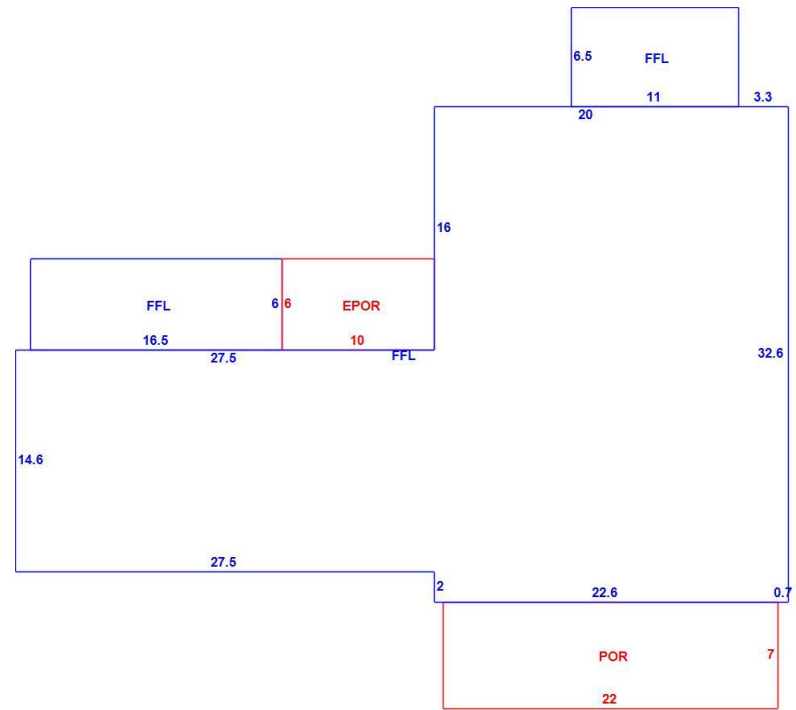

([ParcelSketch.ashx?pid=10740&bid=10740](#))

Building Sub-Areas (sq ft)			<u>Legend</u>
Code	Description	Gross Area	Living Area
FFL	First Floor	1,332	1,332
EPOR	Enclosed Frame Porch	60	0
POR	Open Porch	154	0
		1,546	1,332

Extra Features

Extra Features

Legend

No Data for Extra Features

Land

Land Line Valuation

lblndfront

Size (Acres) 0
Assessed Value \$45,000

Outbuildings

Outbuildings						Legend
Code	Description	Sub Code	Sub Description	Size	Assessed Value	Bldg #
SHED	Shed	S	S	1.00 UNITS	\$0	1

Valuation History

Assessment			
Valuation Year	Improvements	Land	Total
2023	\$59,400	\$45,000	\$104,400
2022	\$59,400	\$45,000	\$104,400
2021	\$59,400	\$45,000	\$104,400

